

(19) World Intellectual Property Organization  
International Bureau



(43) International Publication Date  
11 January 2001 (11.01.2001)

PCT

(10) International Publication Number  
**WO 01/02737 A1**

- (51) International Patent Classification<sup>7</sup>: F15C 5/00, F16K 13/10
- (21) International Application Number: PCT/EP00/06142
- (22) International Filing Date: 30 June 2000 (30.06.2000)
- (25) Filing Language: English
- (26) Publication Language: English
- (30) Priority Data:  
9902474-7 30 June 1999 (30.06.1999) SE
- (71) Applicant (for all designated States except US): **GYROS AB** [SE/SE]; Amersham Pharmacia Biotech AB, Björkgatan 30, S-751 84 Uppsala (SE).
- (72) Inventors; and
- (75) Inventors/Applicants (for US only): **DERAND, Helene** [SE/SE]; Enstavagen 33, S-187 35 Taby (SE). **ANDERSSON, Per** [SE/SE]; Hornsgatan 147, S-117 34 Uppsala (SE). **LARSSON, Anders** [SE/SE]; Tapetersarvagen 14, S-167 72 Bromma (SE).
- (74) Agents: **ROLLINS, Anthony, John et al.**; Nycomed Amersham plc, Amersham Laboratories, White Lion Road, Amersham, Buckinghamshire HP7 9LL (GB).
- (81) Designated States (national): AE, AG, AL, AM, AT, AU, AZ, BA, BB, BG, BR, BY, BZ, CA, CH, CN, CR, CU, CZ, DE, DK, DM, DZ, EE, ES, FI, GB, GD, GE, GH, GM, HR, HU, ID, IL, IN, IS, JP, KE, KG, KP, KR, KZ, LC, LK, LR, LS, LT, LU, LV, MA, MD, MG, MK, MN, MW, MX, MZ, NO, NZ, PL, PT, RO, RU, SD, SE, SG, SI, SK, SL, TJ, TM, TR, TT, TZ, UA, UG, US, UZ, VN, YU, ZA, ZW.
- (84) Designated States (regional): ARIPO patent (GH, GM, KE, LS, MW, MZ, SD, SL, SZ, TZ, UG, ZW), Eurasian patent (AM, AZ, BY, KG, KZ, MD, RU, TJ, TM), European patent (AT, BE, CH, CY, DE, DK, ES, FI, FR, GB, GR, IE, IT, LU, MC, NL, PT, SE), OAPI patent (BF, BJ, CF, CG, CI, CM, GA, GN, GW, ML, MR, NE, SN, TD, TG).
- Published:  
— With international search report.  
— Before the expiration of the time limit for amending the claims and to be republished in the event of receipt of amendments.

[Continued on next page]

(54) Title: POLYMER VALVES

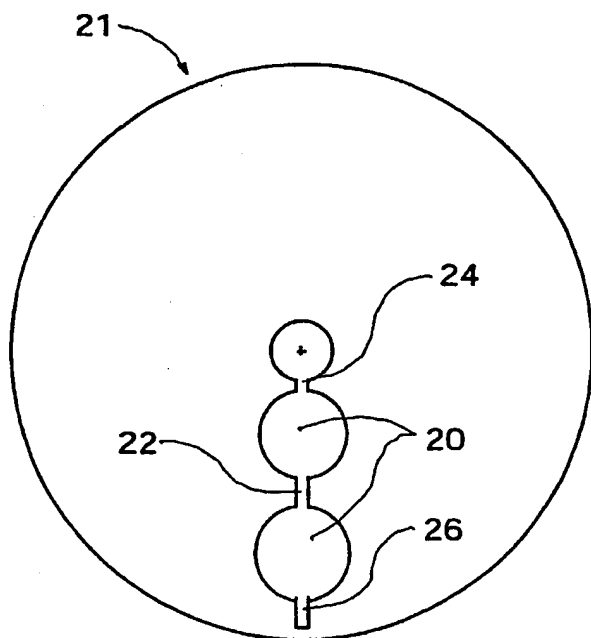

(57) Abstract: The invention relates to a method of controlling flow of liquids in a micro channel structure. It comprises providing in said micro channel structure plugs (34) of polymer material in said structure, said polymer material in a first state blocking said channel from liquid flow, and in a second state providing a free path-way (32) for liquid flow. Energy is selectively applied so as to cause said polymer to enter a desired one of said first or second states. It also relates to a micro channel valve system, comprising a plurality of such plugs (34). Additionally it comprises a chemical reactor, comprising a plurality of micro chambers interconnected by micro channels, having a valve system according to the invention.

WO 01/02737 A1



WO 01/02737 A1



---

*For two-letter codes and other abbreviations, refer to the "Guidance Notes on Codes and Abbreviations" appearing at the beginning of each regular issue of the PCT Gazette.*

## POLYMER VALVES

The present invention relates to devices and methods for controlling liquid flow in micro channel structures.

5

**Background of the Invention**

In recent years micro chamber and channel structures for performing various reactions and analyses have gained wider use. Examples of scientific fields employing devices comprising such micro channel structures are separation techniques (gas chromatography, electrophoresis), cell biology, DNA sequencing, sample preparation, combinatorial chemistry just to mention a few.

The terms "chamber" and "cavity" will in the context of the invention be used interchangeable if not otherwise specified. A chamber or cavity may be a part of a microchannel.

In certain applications it is common to provide a plurality of micro chambers in which reactions are performed, or in which material is incubated for later use etc. It may often be desirable to move the material from one chamber to another. To this end the chambers are connected by micro channels. Obviously it may become necessary to provide some means of closing said channels after the material has passed therethrough, and also it might be desirable to have the possibility to reopen the channel in order to enable more material to pass through.

In WO 94/29400 there is disclosed a microfabricated channel system. This system is designed for i.a. chemical analytical use, such as electrophoresis and chromatography. In one type of structure a channel and/or cavity system is defined between two plane material layers, the recesses which correspond to the channels and cavities, respectively, being formed in one or both of the opposed layer surfaces. The layers are usually bonded together by gluing.

Alternatively they may be fused together if the two layers consist of thermoplastic material.

In WO 9721090 there is disclosed a microfluidic system having a valve function based on the property of a polymer. Opening of the valve function is actuated by external application of heat. However, the valve function has the drawback that disrupting the heating, e.g. by cooling, will not close the valve.

10 The type of systems concerned in the present invention may have channels that are of capillary dimensions for liquid flow/transport. The distance between two opposite walls in a channel may be  $\leq 1000$   $\mu\text{m}$ , such as  $\leq 100$   $\mu\text{m}$ , or even  $\leq 10$   $\mu\text{m}$ , such as  $\leq 1$   $\mu\text{m}$ . This type of systems may also contain one or more distinct chambers connected to  
15 the channels and having volumes being  $\leq 500$   $\mu\text{l}$ , such as  $\leq 100$   $\mu\text{l}$  and even  $\leq 10$   $\mu\text{l}$  such as  $1$   $\mu\text{l}$ . The depths of the chambers may typically be in the interval  $\leq 1000$   $\mu\text{m}$  such as  $\leq 100$   $\mu\text{m}$  such as  $\leq 10$   $\mu\text{m}$  or even  $\leq 1$   $\mu\text{m}$ .

20 The lower limit for the dimensions is set by manufacturing technology limitations, but can be of the nanometer scale, such as  $> 10$  nm,  $> 100$  nm or  $> 1000$  nm.

One or more liquid transportation systems of this type may be placed on a common plate, for instance rotatable, such as a disc of CD-  
25 type. In case of rotatable forms the liquid may be forced through one or more segments of the transportation system by rotating the disc (centripetal force), i.e. the liquid is transported in an outward direction relative the center of the disc. Other types of pressure generating systems may also be used.

30 A device having one or more liquid transportation system comprising channels and chambers with a depth  $\leq 1000$   $\mu\text{m}$ , such as  $\leq 100$   $\mu\text{m}$  or even grounder than  $10$   $\mu\text{m}$  such as  $\leq 1$   $\mu\text{m}$ , are further on called a microfabricated device or a micro chamber and channel  
35 structure/system or a microfluidic structure/system. The

chambers/channels and also the device, structure and system are said to be in the microformat. A microfabricated device typically has its channels and chambers in one plane, such as in the surface of a plate, for instance on a disc. The plate may be circular, oval, 5 rectangular (including in form of a square) or of any other 2D geometric form.

The channels and/or chambers define a flow path pattern in the system, which is delineated by barriers. The barriers can be in form 10 of physical walls, bottoms and tops that are located on or in a planar surface. Hydrophobic barriers combined with aqueous liquids and vice versa for non-polar liquids (see WO 99/58245) have been suggested for defining flow paths and for directing the liquid flow, i.e. to replace the walls and the like in microfabricated devices. 15 There is typically also a second surface applied against the pattern and acting as a top covering the pattern and preventing evaporation of liquid (except for minor parts/dots intended for addition/removal of liquids).

20 Liquid transportation systems of the type referred to above may also contain valves, pumps, filters and the like.

As mentioned above, in a particular application, a chamber and channel structure is provided in or on a plastic disk. Two or more 25 micro chambers in sequence are aligned radially via a channel. When the disk is spun, material in a chamber located near the center will migrate through the channel to an outwardly located chamber, thereby providing a controllable flow path for reagents to pass from one chamber to another.

30 However, it is of course difficult to control the flow. The spinning of the disk could be correlated with some position indicating means for locating a sample at a certain point in time, but absent a valve function, there will always be some "spill over" between chambers.

35

It is known to employ so called stimulus-responsive materials for a number of purposes, e.g. in micro-machines, separation, drug delivery systems etc. This type of material and preparation thereof is discussed in *Radiat. Phys. Chem.* Vol. 46, No 2, pp185-190,1995, in an article entitled "Thermo-responsive gels", by Ichijo et al.

One possible use is an automatic gel valve provided in a tube. A net is attached to cover the outlet of the tube and a porous PVME (poly(vinyl methyl ether)) gel plug is inserted into the tube and positioned on the net. In response to hot water flowing out through the tube, the gel collapses and the hot water was allowed to freely pass through. When cold water is introduced, the gel reversibly regains its swollen state, thereby blocking the outlet. This concept for a valve function is not possible to apply in a multi-valve structure, since only one gel plug can be inserted in a tube in this way. The already introduced plug will hinder the insertion of subsequent plugs downstream. It is also impossible to arrange subsequent plugs upstream of the already positioned plug, since it will be impossible to provide the obstructing net structure for the upstream located plugs.

In US-5,547,472 (Onishi et al) a perforated balloon attached to a catheter was coated with a stimulus-responsive polymer, enabling the pores to be closed or opened in response to e.g. temperature changes. The polymer is bonded to the surface of the balloon and does not appear to be introduced into the pores.

During the priority year, approaches within the same field as the invention have been published by Beebe et al (*Nature* 404 (April 6, 2000) 588-590), and Liu et al and Madou et al (in *Micro Total Analysis System 2000*, Ed. Van der Berg et al., *Proceedings of the  $\mu$ TAS 2000 Symposium held at Enschede, the Netherlands 14-18 May, 2000, pages 45-48 and 147-150, respectively)*

35 **Summary of the Invention**

Thus, there is a need for means and methods of controlling the liquid flow in micro channel structures, which do not suffer from the problems discussed above. In particular it is desirable and an object of the invention to provide a plurality of selectively operable valve functions arranged one after the other in one capillary channel, optionally between reaction chambers in a micro channel structure.

10 This object is achieved with the method as claimed in claim 1, and the micro channel valve system as claimed in claim 13, and the chemical reactor as claimed in claim 19, respectively.

Thereby an intelligent polymer (= stimulus-responsive polymer) is employed, having the capability of responding to externally applied energy (stimulus), by changing a property of the polymer so as to change its volume, thereby occupying more or less of the space in which the polymer is confined. For intelligent polymers the change is reversible meaning that once a stimulus (energy) applied is removed then the polymer returns back to its starting volume. By applying energy of appropriate type and magnitude it will be possible to cause a volume change in a desired direction (increase or decrease) to either open or close a pathway through a valve comprising this kind of polymer in a microchannel. It follows that the term "applying energy" includes both positive and negative energy values, i.e. removal and supplying energy.

The required type of energy depends, among others, on the polymer, and includes the so called free energy of chemical systems. The application of energy may take place by heating, irradiation (UV, IR etc) etc or by changing the chemical composition of the liquid in contact with the polymer (e.g. change of pH, of solvent, of concentrations of compounds reacting reversible with the polymer etc). By the term "externally applied" is meant external to the polymer, i.e. application of energy has to take place either via the

walls surrounding the polymer or via the liquid in contact with the polymer. This also includes applying the energy to a liquid present in a channel for transport therein by the liquid to the stimulus-responsive polymer in the inventive valve.

5

In a preferred embodiment the polymer responds to externally applied heat or to external cooling by undergoing a conformational change.

In another embodiment the polymer responds to an applied electrical  
10 field.

In still another embodiment the polymer responds to light.

The polymer may in a further embodiment respond to magnetic fields.  
15

Preferably the polymer is provided in gel form (solvated form, closed valve), disposed inside a channel and retained in a fixed position, or even anchored to at least one surface of said channel. When activated, the polymer contracts (the gel collapses or  
20 desolvates, opened valve) leaving a free pathway in the channel along that surface or those surfaces to which the polymer is not anchored.

#### Brief Description of the Drawings

25 The invention will now be described with reference to non-limiting examples and with reference to the attached drawings, in which

Fig. 1 shows an example of a micro channel and chamber structure according to WO 94/29400, wherein the invention  
30 may be employed;

Fig. 2 shows a top view of the structure of Fig. 1 in case the microstructure comprises channels and chambers;



Fig. 3a is a cross section through a channel of a micro channel structure wherein a plug of a stimuli responsive gel is located in a channel, without being anchored to any surface, and in a swollen state;

5

Fig. 3b is the same cross section as in Fig. 3a, where the polymer has been stimulated to collapse, thereby providing a free flow path;

10

Fig. 3c is a cross section through a channel of a micro channel structure wherein a plug of a stimuli responsive gel is anchored in one surface of the channel, and in a swollen state;

15

Fig. 3d is the same cross section as in Fig. 3a, where the polymer has been stimulated to collapse, thereby providing a free flow path;

20

Fig. 3e shows a cross section of a channel in which the polymer has been anchored to three surfaces of a channel, and is in a contracted state;

25

Fig. 4a is a perspective view, partially in cross section of a channel having a grid as a mechanical means to prevent a gel plug from moving;

30

Fig. 4b is a perspective view, partially in cross section, of a channel having a plurality of pointed protrusions provided over a surface of a channel, providing anchoring means to prevent a gel plug from moving;

35

Fig. 4c is a perspective view, partially in cross section of a channel having side rooms in which a gel plug can be inserted, to prevent it from moving;

Fig. 5a is microphotograph of the gel prepared in Example 1 in a swollen state; and

Fig. 5b is the same gel as shown in Fig. 5a in contracted  
5 state.

#### Detailed Description of Preferred Embodiments of the Invention

For the purposes of this application, the term "chemical reactor"  
10 shall be taken to mean any structure capable of housing chemical and/or biological reagents or reaction partners, and in which these agents can react, i.e. interact with each other, for the purposes of synthesis, analysis, separation or other chemical, physical-chemical or biological processes.

15

In Fig. 1 there is shown a cross section of a microfabricated channel structure, which forms the subject matter of WO 94/29400.

The structure in Fig. 1 comprises two elements 11, 12 having opposed  
20 plane surfaces bonded together. One or both of the surfaces have open channels 14 and or cavities provided therein. The bonding may be effected by applying a thin layer 13 of a solution of a material capable of fusing with and having a lower melting point than that of the materials of the two element surfaces, in a solvent which  
25 substantially does not dissolve the element surface material or materials. Solvent is removed, the element surface are brought together and heated to melt the layer 3 so as to bond the surfaces together.

30 In Fig. 2 a top view of a simplified, exemplary CD (compact disk) type of device 21 is shown, having a chamber and channel structure that may be made e.g. in accordance with the disclosure of WO 94/29400.

Thus, the disk comprises two chambers 20 connected via a channel 22. There is also provided an inlet channel 24 having an upward opening (not shown) for the introduction of reagents, and an outlet channel 26, having an opening (not shown) for the discharge of reacted  
5 material.

This particular configuration could be used for e.g. performing a sequential reaction in two steps, one in each chamber 20, the first step being carried out in the innermost (with respect to the radial  
10 direction) chamber, and the second in the outermost chamber. This structure thus constitutes a "chemical reactor" as defined above, e.g. for carrying out a synthetic reaction. However, in order to be able to do this in a controlled way, a valve function according to the invention is provided in at least the connecting channel 22 and  
15 the outlet channel 26. Thereby the second chamber can be isolated from the first, and the reaction in the first chamber can be carried out to the desired extent. Thereafter the valve is activated and the reaction mixture in the first chamber can be transported into the second chamber where new reagents may be present and the second step  
20 is carried out.

The driving force for the transport of material between the chamber can be a centrifugal field created by spinning the disk. For electrophoresis applications, an electric field would be employed.  
25 If a column like configuration is employed, i.e. the chambers are arranged vertically, the first above the second, gravity could be used as driving force for the transport.

Now the valve function according to the invention will be described  
30 in detail with reference to Figs 3a-3e.

According to a first embodiment of the invention (Figs. 3a and 3b), a polymer 34 capable of effecting a structural change in response to a stimulus (stimulus responsive polymer), is placed in a channel 32  
35 in a channel and chamber micro structure of the type described

above. When exposed to said stimulus, the polymer will collapse or contract, and leave at least a fraction of the channel in which it is situated free for liquid to flow there through

5 According to another embodiment of the invention, a polymer capable of effecting a structural change in response to a stimulus, is anchored in a channel 32 in a channel and chamber micro structure of the type described above. The polymer is anchored in such a way that when stimulated to collapse or contract, it has the possibility to  
10 leave at least a fraction of the channel in which it is situated free for liquid to flow through. Normally the cross section of the channels will be rectangular (see Fig. 3c), that is there will be four walls 31a-d, essentially perpendicular to each other. For a configuration of this type, the polymer 34 would preferably be  
15 anchored (schematically indicated at 36) to one, two or even three of the walls in said channel. This is shown schematically in Fig. 3c, where the polymer is shown to be in its swollen state, thereby blocking the channel completely. In fig. 3d a situation is shown where the polymer has been stimulated, e.g. by heating, such that it  
20 collapses, thereby opening the channel 32 to liquid flow. Finally, in Fig. 3e an embodiment is shown where the polymer gel 34 has been anchored in three walls of a channel. When stimulated by e.g. heat, the polymer strives to contract, but since it is attached to the walls on three sides, it will form a concave upper surface, leaving  
25 a free pathway 32 for fluid flow.

There are two main alternatives for bonding the stimulus-responsive polymer to the channel wall:

- (a) chemical bonding/anchoring including covalent attachment  
30 or physical adsorption (for instance via ionic forces, van der Waals forces, dipole-dipole interactions etc, and
- (b) retainment by mechanical means, for instance in chambers with narrow outlets and/or inlets (obstructions).

Alternative (a) requires that the polymer material is only partially  
35 bonded to the channel surface, i.e. there should be a non-bonded

part leaving a free fluid pathway between the polymer material and the channel surface when the polymer material is in a contracted state. Thus, this variant requires that bonding is occurring only on a fraction of the contact area between the microchannel surface and the plug in a swelled state.

The stimulus-responsive polymer may be bonded to the channel wall e.g. by effecting cross-linking reaction between polymer units of the wall material and the stimulus-responsive polymer respectively (= covalent anchoring/attachment/bonding). There are many ways of anchoring the polymer available to the skilled man, a couple of which are given as non-limiting examples below.

1) For polymers prepared by radical polymerization (e.g. polyacrylamides, polyacrylates, polymethacrylates or polyvinylamides) the channel surface can be modified to contain reactive groups capable of participating in the polymerization. Such groups can be active as initiators (e.g. azo or peroxide groups), copolymerizable groups (e.g. double bonds) or chain transfer groups (e.g. thiols or tertiary amines). Examples of ways to introduce the reactive groups are listed below:

- reacting glass, silica or silicon surfaces with a methacryl silane, a vinyl silane or a thiol silane.
- coating various surfaces with a thin layer of a polymer containing double bonds, such as allyl glycidyl agarose, polybutadiene or an unsaturated polyester resin.
- subjecting the polymer surfaces to plasma (glow discharge) treatment under such conditions that double bonds are formed on the surface.

2) More generally applicable ways could be to provide a rough surface with possibilities for mechanical interlocking of the polymer or to create an interpenetrating polymer network in the interphase between the polymer and a polymeric substrate.

It is also possible to use mechanical means to retain the polymer gel in a fixed position. These options will be described further in the Examples below.

5

The material in said micro channel surface can be subjected to a variety of surface treatments, such as wet etching, plasma treatment, corona treatment, UV treatment, grafting, adsorption coating, in order to improve the surface properties.

10

The stimulus, which can cause a structural change of the polymer in the pores, is selected from pH, ion, solvent composition, chemical substance, heat, electricity and light such as ultraviolet radiation. The structural change of polymer is swelling and contraction. The invention utilizes the nature of intelligent polymers that an external stimulus can trigger a reversible structural change between a solvated state and a desolvated state.

An important feature of the polymers used in the valves of the present invention is that they switch from a swelled state (solvated state) to contracted state (desolvated state) or vice versa in a reversible manner as discussed elsewhere herein. Thus the state at hand is dependent on the level/intensity of a stimulus applied, meaning for instance that above a certain critical level/intensity (magnitude) of the stimulus one state is at hand. For chemical substances the level/intensity typically corresponds to concentrations. When going below the critical level, the polymer is transformed to the other state. For a thermo-responsive polymer having a lower critical solution temperature (LCST), an increase in temperature passing the LCST will cause a switch from the solvated to the desolvated state and vice versa when changing the temperature in the opposite direction. When using a polymer having an upper critical solution temperature (UCST) the temperature increase will result in a switch from a desolvated state to a solvated state.

35

For example, a polymeric electrolyte gel is known to undergo a structural change owing to an osmotic pressure change by electrolyte ions in the polymer chain and interaction of electrolyte ions with a solvent. Then the polymeric electrolyte gel undergoes reversible contraction in response to a change of pH, solvent composition and ion concentration. An electric stimulus (in terms of potential, voltage and current) can be effectively utilized for the polymers contraction response since it can bring a local change of pH or ion concentration. Among non-ionic polymers, e.g. polymers and copolymers of vinyl methyl ether and N-isopropylacrylamide undergo a change between hydrophilic and hydrophobic states in response to heat and provide a contraction response in an aqueous solvent. Then by utilizing heat generation by electric resistance or heat of mixing, the effective diameter of the pores can be changed. A stimulus given by a chemical substance is such that polymer chains swollen in pores are contracted if a complex is formed by utilizing hydrogen bonds or the like. For example, if a carboxylic polymer swollen in pores is contacted with an agent containing a polyether, the polycarboxylic acid reacts with the polyether to form a high molecular weight complex with concomitant contraction, resulting in the pores increasing an open passage for fluids. The valves according to the invention are provided at selected points in a micro channel system. They can be prepared e.g. by photopolymerizing the stimulus responsive polymer in situ, where the irradiation is made through a mask, such that the polymer is only formed in the illuminated areas. After e.g. heat contraction of the polymer, residual monomers can be washed out of the channel system. It is also conceivable as an alternative to irradiation with light to employ microwaves, electron beams or any other type of radiation that is possible to mask off.

A further conceivable method is to form the polymer in the entire channel system, and then selectively degrading it (e.g. by light or radiation) everywhere except in the designated areas. The

degradation products would then be washed out after contraction of the valve areas.

The invention will now be illustrated by way of the following non-limiting examples.

#### EXAMPLES

In the following Examples a CD (compact disk) type device comprising micro channels and chambers as shown schematically in Fig. 2 can be used.

#### Example 1

N-isopropylacrylamide (0.5 g) and N,N-methylene bisacrylamide (0.01 g) was dissolved in water (4.0 ml). 0,1 ml of a photo-initiator (Irgacure 184, Ciba-Geigy, 100 mM in ethylene glycol) was then diluted in 0.5 ml water, before mixing it with the monomer solution. A drop of the monomer solution was transferred to a channel in a microfabricated CD disc made of plastic (polycarbonate), and covered by a microscope glass cover slip. The monomer solution inside the channel was then illuminated with UV light through the glass cover slip for 10 minutes in order to polymerize the monomers .

When the polymerization was completed, a hydrostatic pressure using an aqueous dye solution was applied to the inlet of the channel. No liquid was seen to flow through the channel (see Fig. 5a). The CD disc was then left at 40°C for 5 minutes, and a hydrostatic pressure was again applied to the channel. This time the liquid immediately flowed through the channel (see Fig. 5b). The CD disc was then allowed to return to room temperature, and again a hydrostatic pressure was applied. No liquid flowed through the channel. A picture of the valve before and after heat treatment is shown in Fig. 5a and 5b respectively.



## Example 2

A microscope cover glass was wiped with methacryloxytriethoxysilane and rinsed with water and ethanol. A gel-forming solution was prepared from 0.5 g N,N-diethylacrylamide, 10 mg N,N'-methylenebisacrylamide, 6.5 ml distilled water and 0.1 ml of a 0.1 M solution of Irgacure-184 in ethylene glycol. A droplet of this solution was placed in a channel of a polycarbonate CD disc having a recessed 100  $\mu\text{m}$  deep channel pattern on its surface, and a microscope cover glass was placed over the droplet with the treated side facing downwards. The package was placed on a cold steel plate under an array of low pressure mercury lamps and illuminated for 5 min to polymerize the monomers. A transparent gel was formed in the channels, which turned opaque upon heating to 45°C, and again turned transparent when it was cooled below room temperature. An aqueous dye solution was able to penetrate the channel system at 45°C, thus proving that a free path-way for fluid flow was provided. At room temperature the channel was blocked and no dye solution penetrated. The cover glass was then pryed.

20

## Example 3

A gel-forming solution was prepared from 0,5 g N,N-diethylacrylamide, 10 mg N,N'-methylenebisacrylamide, 6,5 ml distilled water and 0,1 ml of a 0,1 M solution of Irgacure-184 in ethylene glycol. A droplet of this solution was placed in a channel of a polycarbonate CD disc having a recessed 100  $\mu\text{m}$  deep channel pattern on its surface, and a microscope cover glass was placed over the droplet. The package was placed on a cold steel plate under an array of low pressure mercury lamps and illuminated for 5 min to polymerize the monomers. A transparent gel was formed in the channels, which turned opaque upon heating to 45°C, and again turned transparent when it was cooled below room temperature. An aqueous dye solution was able to penetrate the channel system at 45°C, thus

35

proving that a free path-way for fluid flow was provided. At room temperature the channel was blocked and no dye solution penetrated.

#### Example 4

5

The same procedure as in Example 2 was repeated, but the cover glass was partially masked with an aluminum mask during illumination. The thermo-responsive gel was formed only in the illuminated parts of the channel system.

10

#### Example 5

A micro channel structure in a microfabricated CD disc 40 made of plastic (polycarbonate) is made, having the structure as shown schematically in perspective in Fig. 4. In this case there are provided mechanical obstructions in the channel 44 at the points where the valve is desired. These obstructions can be in the form of a grid of vertically arranged pins 42, as shown in Fig. 4a which is a cross section through a substrate in which a channel having such obstructions has been made. The gel (not shown) is polymerized in the channel upstream of the grid, using the same procedure as in Example 1.

When the polymerization is completed, a hydrostatic pressure using an aqueous dye solution is applied at room temperature to the inlet of the channel. No liquid was seen to flow through the channel. The CD disc is then left at 40°C for 5 minutes, and a hydrostatic pressure is again applied to the channel. This time the liquid immediately flowed through the channel. The CD disc is then allowed to return to room temperature, and again a hydrostatic pressure is applied. No liquid flowed through the channel.

30

#### Example 6

A micro channel structure in a microfabricated CD disc made of plastic (polycarbonate) is made, having the structure as shown schematically in Fig. 4b. In this case there are provided mechanical obstructions in the form of protrusions 46 in the channel, distributed over the area where the polymer plug is to be located, i.e. at the point where the valve is desired. These obstructions can be shaped in the same way as those shown in Fig. 4a, or could be shorter, rather like nipples, as shown in Fig. 4b, and will act as retaining elements for the gel. The gel is polymerized (not shown) in the channel in the area where the pins are located, using the same procedure as in Example 1. Thus, the pins will be molded inside the gel plug, thereby preventing it from moving in the channel.

When the polymerization is completed, a hydrostatic pressure using an aqueous dye solution is applied at room temperature to the inlet of the channel. No liquid is seen to flow through the channel. The CD disc is then left at 40°C for 5 minutes, and a hydrostatic pressure is again applied to the channel. This time the liquid immediately flowed through the channel. The CD disc is then allowed to return to room temperature, and again a hydrostatic pressure is applied. No liquid flowed through the channel.

#### Example 7

Of course other anchoring methods may be employed. One alternative is to provide a widened portion of the channel, such as the "side rooms" 48 as shown schematically in fig. 4c. A gel plug is provided such that it is "anchored" in the side rooms of the channel 44. If the side rooms are made large enough, the plug will be effectively prevented from moving in the channel under hydrostatic pressure.

## CLAIMS

1. A method of controlling flow of liquids in a micro channel  
5 structure comprising a micro channel, said method comprising the  
steps of:

providing in at least one position, and preferably in a  
plurality of positions in said micro channel structure a plug of  
10 polymer material in each said position, said polymer material having  
the property of responding to externally applied energy by changing  
its volume, said polymer material in a first state providing a first  
volume blocking said channel from liquid flow, and in a second state  
providing a second volume giving a free path-way for liquid flow;  
15 and

selectively applying energy of appropriate type and  
magnitude to the polymer material of a selected one of said at least  
one plug so as to cause the volume change between said two states,  
20 thereby bringing said polymer to a desired one of said first or  
second states.

2. The method of claim 1, wherein said polymer material is  
selected from the group of polymers consisting of heat responsive  
25 polymers, light responsive polymers, magnetically responsive  
polymers, pH responsive polymers and polymers responsive to electric  
fields.

3. The method of anyone of claims 1-2, comprising that the  
30 said polymer material at least partially is anchored to a surface  
inside said micro channel.

4. The method of anyone of claims 1-3, wherein the polymer  
material is chemically bonded to the material in said micro channel  
35 surface.

5. The method of anyone of claims 1-3, wherein the polymer is anchored in the micro channel by means of a mechanical obstruction in the microchannel.

5

6. The method of any preceding claim, wherein the material in said micro channel surface comprises a material selected from plastics, e.g. polycarbonates, polystyrenes, cycloolefin polymers; rubbers; metals; carbon; inorganic oxides, nitrides, carbides; silicon; quartz.

10

7. The method of any preceding claim, wherein the material in said micro channel surface has been subjected to a surface treatment, such as wet etching, plasma treatment, corona treatment, UV treatment, grafting, adsorption coating.

15

8. The method of any preceding claim, wherein the step of applying energy comprises heating the polymer material and the polymer material comprises a heat responsive polymer.

20

9. The method of claim 8, wherein said heating is performed by irradiating with electromagnetic radiation, e.g. light, microwaves or infra red radiation, and the polymer material comprises a polymer responsive to electromagnetic radiation, e.g. light, microwaves or infra red radiation).

25

10. The method of any of claims 1-7, wherein the polymer is light sensitive and the step of applying energy comprises illuminating the polymer material with light of a suitable wave length, and the polymer material comprises a light responsive polymer.

30

11. The method of any of claims 1-7, wherein the step of applying energy comprises exposing the polymer material to a

magnetic field, and the polymer material comprises a magnetic responsive polymer..

12. The method of any of claims 1-7, wherein the step of  
5 applying energy comprises exposing the polymer material to an electric field, and the polymer material comprises a polymer responsive to electricity.

13. A micro channel valve system, comprising  
10 a plurality of plugs (34) of a polymer material having the property of responding to externally applied energy by changing its volume, said plugs being provided at selected locations within at least one channel (31a-d) of a micro channel structure (20, 22, 24,  
15 26).

14. The valve system according to claim 13, wherein said polymer material is selected from the group of polymers consisting of heat responsive polymers, light responsive polymers, magnetically  
20 responsive polymers, polymers responsive to electric fields.

15. The valve system according to anyone of claims 13-14, said polymer material comprising a polymer being selected from the group of polymers consisting of polyvinylethers, polyacrylamides,  
25 polyvinylamides, polyalkyleneglycols, celluloseethers, polyacrylates, polymethacrylates; and polymers of N,N-diethylacrylamide, N,N-diethylbisacrylamide, N-vinylcaprolactam, and a polymer obtained by the polymerization of N-isopropylacrylamide and N,N-methylene bisacrylamide.

30 16. The valve system according to any of claims 13-15, wherein said polymer material is anchored inside said micro channel by chemical bonding.

17. The valve system according to any of claims 13-16, wherein said polymer plug is anchored only over a fraction of the contact surface between the plug in a swelled state and the inner surface of said micro channel (partial anchoring).

5

18. The valve system according to any of claims 13-16, wherein said polymer plug is retained in a fixed position inside said micro channel by mechanical means.

10 19. A chemical reactor, comprising a plurality of micro chambers (20) interconnected by micro channels (22, 24, 26), having a valve system according to any of claims 13-18, provided in at least one of said micro channels.

15 20. The chemical reactor as claimed in claim 19, wherein said chambers and channels are provided in a planar substrate (21).

21. The chemical reactor as claimed in 20, wherein the substrate is of a material selected from the group consisting of  
20 plastics e.g. polycarbonates, polystyrenes, cycloolefin polymers; rubbers; metals; carbon; inorganic oxides, nitrides, carbides; silicon; quartz.

22. The chemical reactor as claimed in any of claims 20-21,  
25 wherein the substrate is circular.

23. The chemical reactor as claimed in any of claims 20-21, wherein the substrate is rectangular.

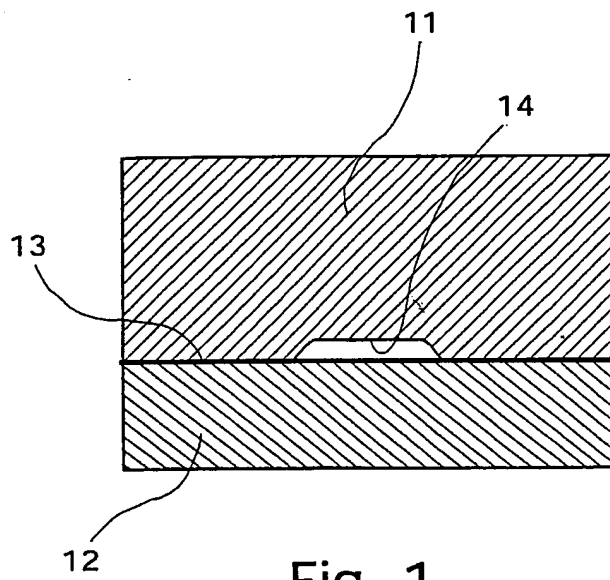

Fig. 1



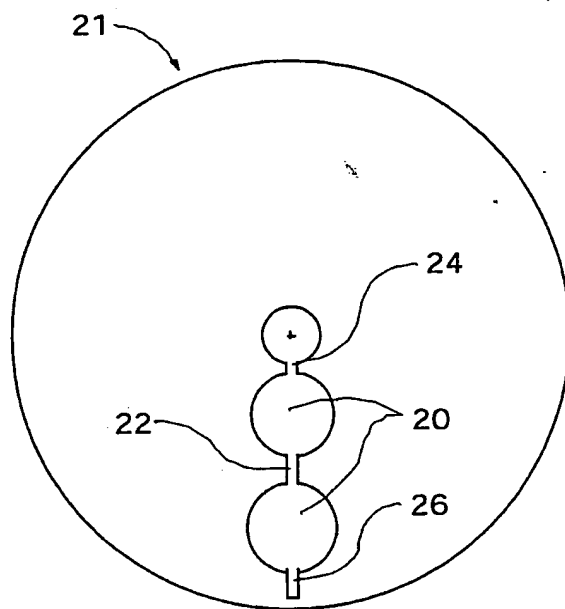

Fig. 2

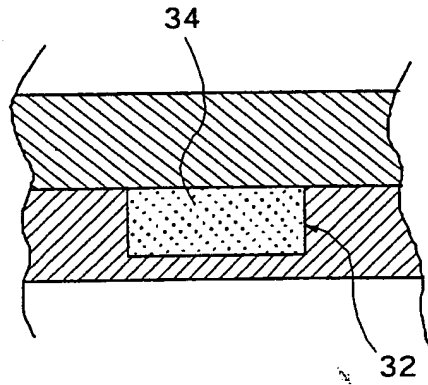

Fig. 3a

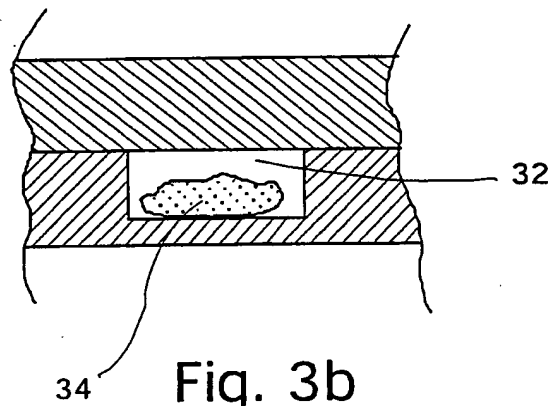

Fig. 3b

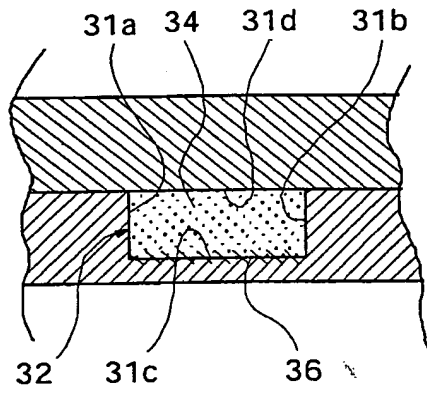

Fig. 3c

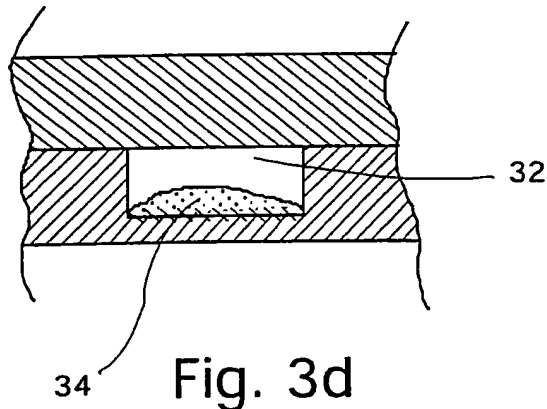

Fig. 3d

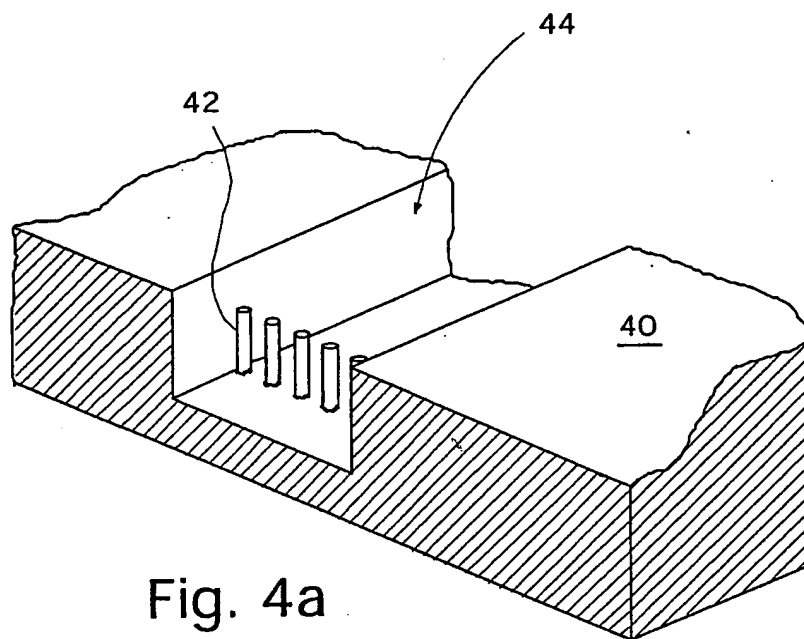

Fig. 4a

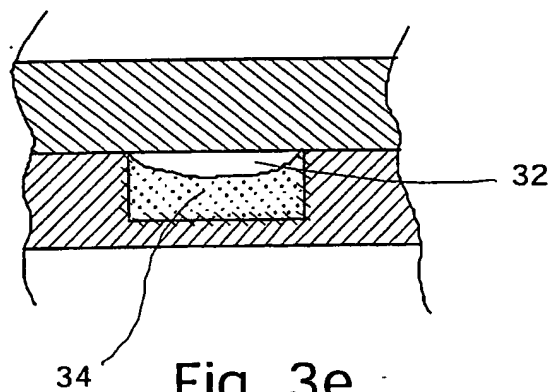

Fig. 3e

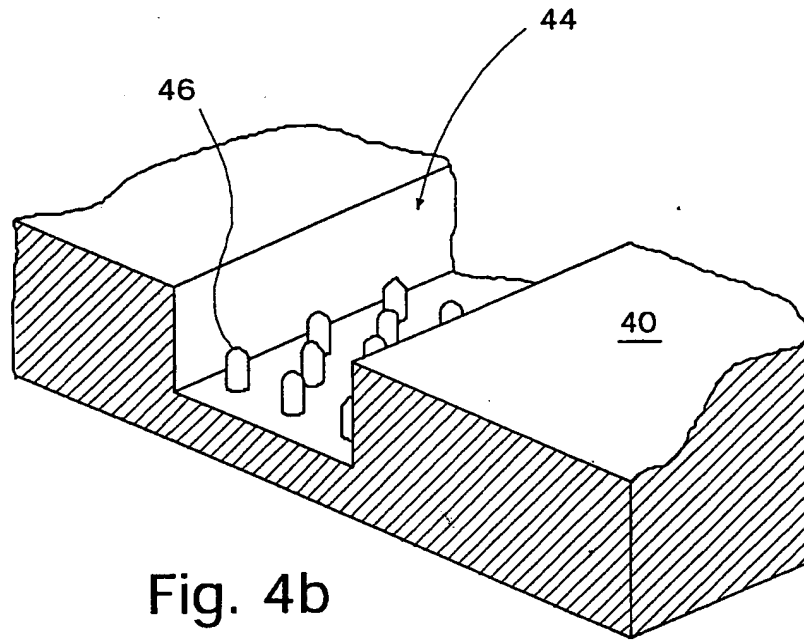

Fig. 4b

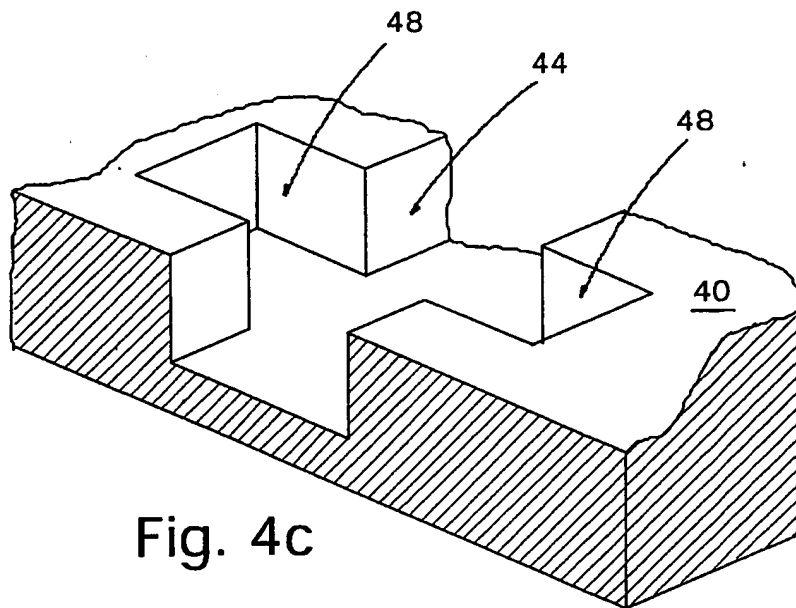

Fig. 4c

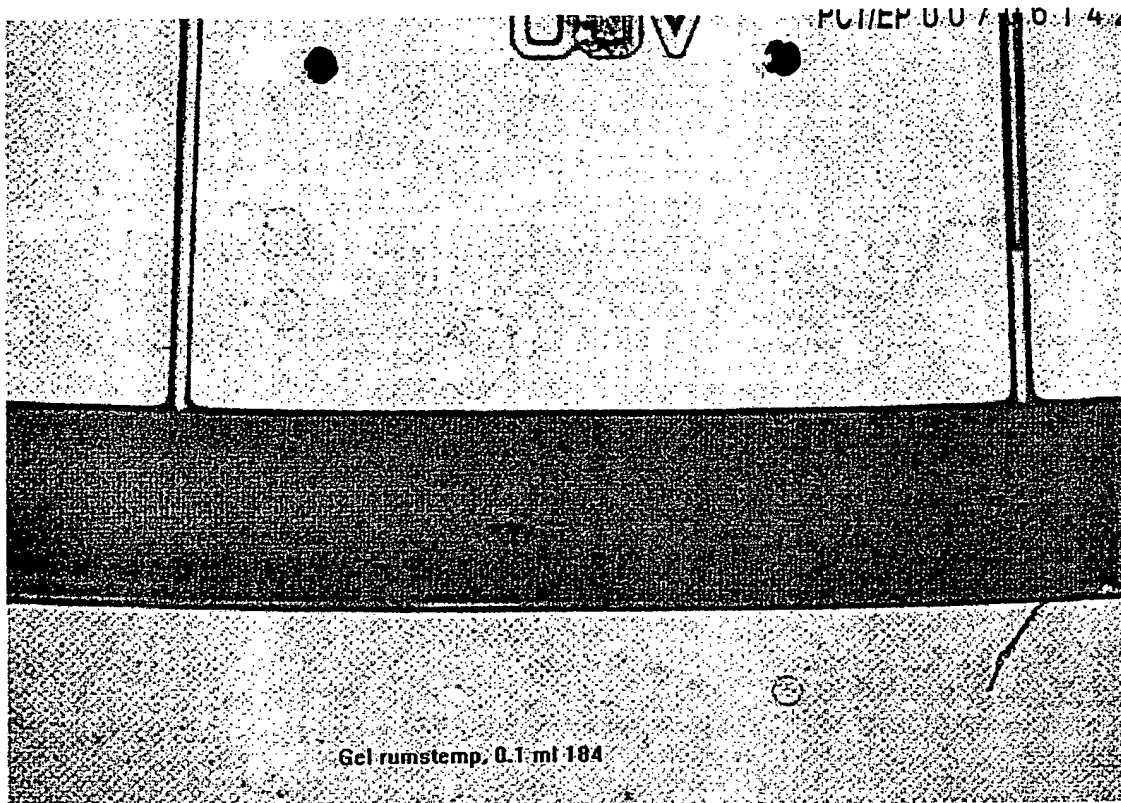

FIG 5A

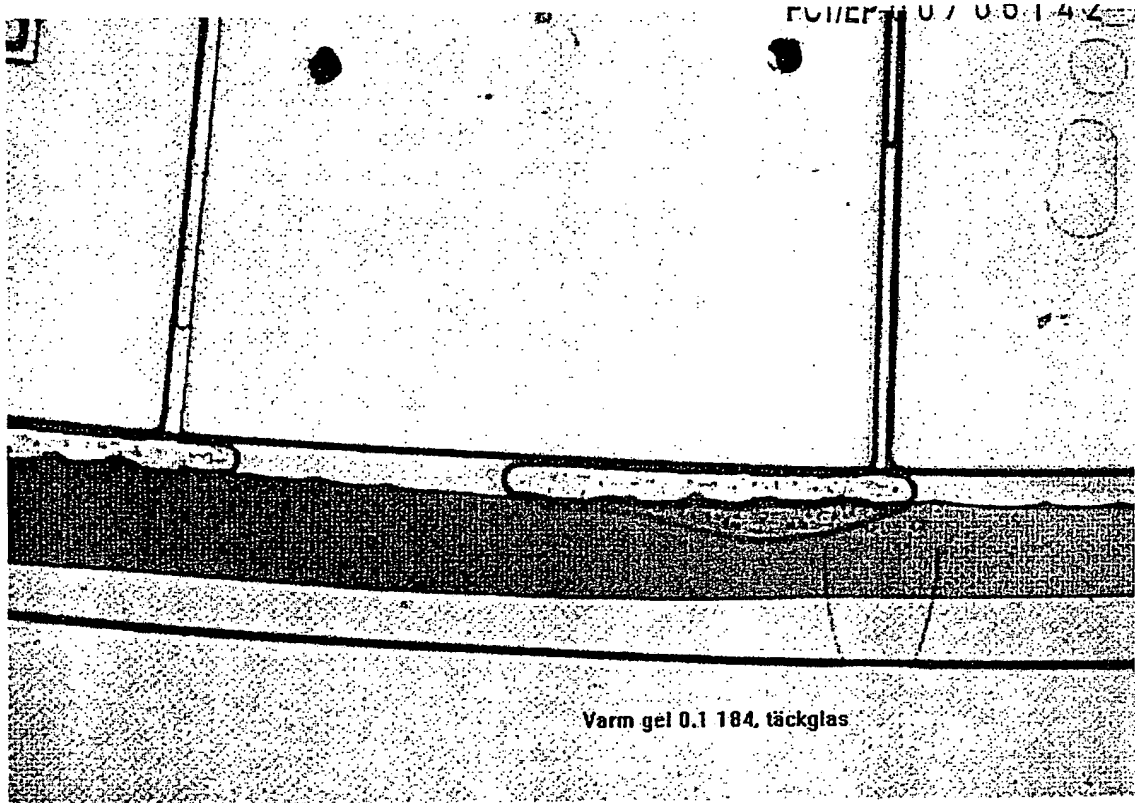

FIG 5B

# INTERNATIONAL SEARCH REPORT

International Application No

PCT/EP 00/06142

**A. CLASSIFICATION OF SUBJECT MATTER**  
 IPC 7 F15C5/00 F16K13/10

According to International Patent Classification (IPC) or to both national classification and IPC

**B. FIELDS SEARCHED**

Minimum documentation searched (classification system followed by classification symbols)  
 IPC 7 F15C F16K

Documentation searched other than minimum documentation to the extent that such documents are included in the fields searched

Electronic data base consulted during the international search (name of data base and, where practical, search terms used)

EPO-Internal, PAJ

**C. DOCUMENTS CONSIDERED TO BE RELEVANT**

Category *	Citation of document, with indication, where appropriate, of the relevant passages	Relevant to claim No.
A	US 5 643 247 A (J.M. FERNANDEZ ET AL.) 1 July 1997 (1997-07-01) column 4, line 66 -column 5, line 9 column 15, line 1 - line 48; figures 15A-15C	1
A	----- ICHIJO H ET AL: "Thermo-responsive gels" RADIATION PHYSICS AND CHEMISTRY, NL, ELSEVIER SCIENCE PUBLISHERS BV., AMSTERDAM, vol. 46, no. 2, 1 August 1995 (1995-08-01), pages 185-190, XP004051389 ISSN: 0969-806X cited in the application the whole document	1

Further documents are listed in the continuation of box C.

Patent family members are listed in annex.

\* Special categories of cited documents :

- \*A\* document defining the general state of the art which is not considered to be of particular relevance
- \*E\* earlier document but published on or after the international filing date
- \*L\* document which may throw doubts on priority claim(s) or which is cited to establish the publication date of another citation or other special reason (as specified)
- \*O\* document referring to an oral disclosure, use, exhibition or other means
- \*P\* document published prior to the international filing date but later than the priority date claimed

- \*T\* later document published after the international filing date or priority date and not in conflict with the application but cited to understand the principle or theory underlying the invention
- \*X\* document of particular relevance; the claimed invention cannot be considered novel or cannot be considered to involve an inventive step when the document is taken alone
- \*Y\* document of particular relevance; the claimed invention cannot be considered to involve an inventive step when the document is combined with one or more other such documents, such combination being obvious to a person skilled in the art.
- \*Z\* document member of the same patent family

Date of the actual completion of the international search

Date of mailing of the international search report

1 November 2000

08/11/2000

Name and mailing address of the ISA  
 European Patent Office, P.B. 5818 Patentlaan 2  
 NL - 2280 HV Rijswijk  
 Tel. (+31-70) 340-2040, Tx. 31 651 epo nl,  
 Fax: (+31-70) 340-3016

Authorized officer

Goetz, P



# INTERNATIONAL SEARCH REPORT

Information on patent family members

International Application No

PCT/EP 00/06142

Patent document cited in search report	Publication date	Patent family member(s)	Publication date
US 5643247 A	01-07-1997	AT 168497 T	15-08-1998
		AU 676023 B	27-02-1997
		AU 6231494 A	15-08-1994
		CA 2153990 A	04-08-1994
		DE 69411709 D	20-08-1998
		EP 0680659 A	08-11-1995
		JP 8510597 T	05-11-1996
		WO 9417538 A	04-08-1994

---